



STEELDRIVE II

High precision, temperature compensating
focusing motor for heavy loads

MADE IN GERMANY



**Baader
Steeldrive II
Motor Unit**

#2957265



- EN ver. 03/2019 -



BAADER PLANETARIUM GMBH

Zur Sternwarte 4 • D-82291 Mammendorf • Tel. +49 (0) 8145 / 8089-0 • Fax +49 (0) 8145 / 8089-105
www.baader-planetarium.com • kontakt@baader-planetarium.de • www.celestron.de

Dear customer,

congratulations for purchasing a Steeldrive II (SD II) motor focuser. This manual describes installation and operation of the **motor unit**.

In case of questions or problems, please consult the FAQ on our website or contact your dealer or us. www.baader-planetarium.com/en/steeldrive2

The Baader Steeldrive II motor focuser consists of the motor unit and the controller. Both units are also available separately. You always need one controller to operate one motor unit. But you can use one controller with several motor units one at a time – you only need to plug it into the motor unit which you want to use.

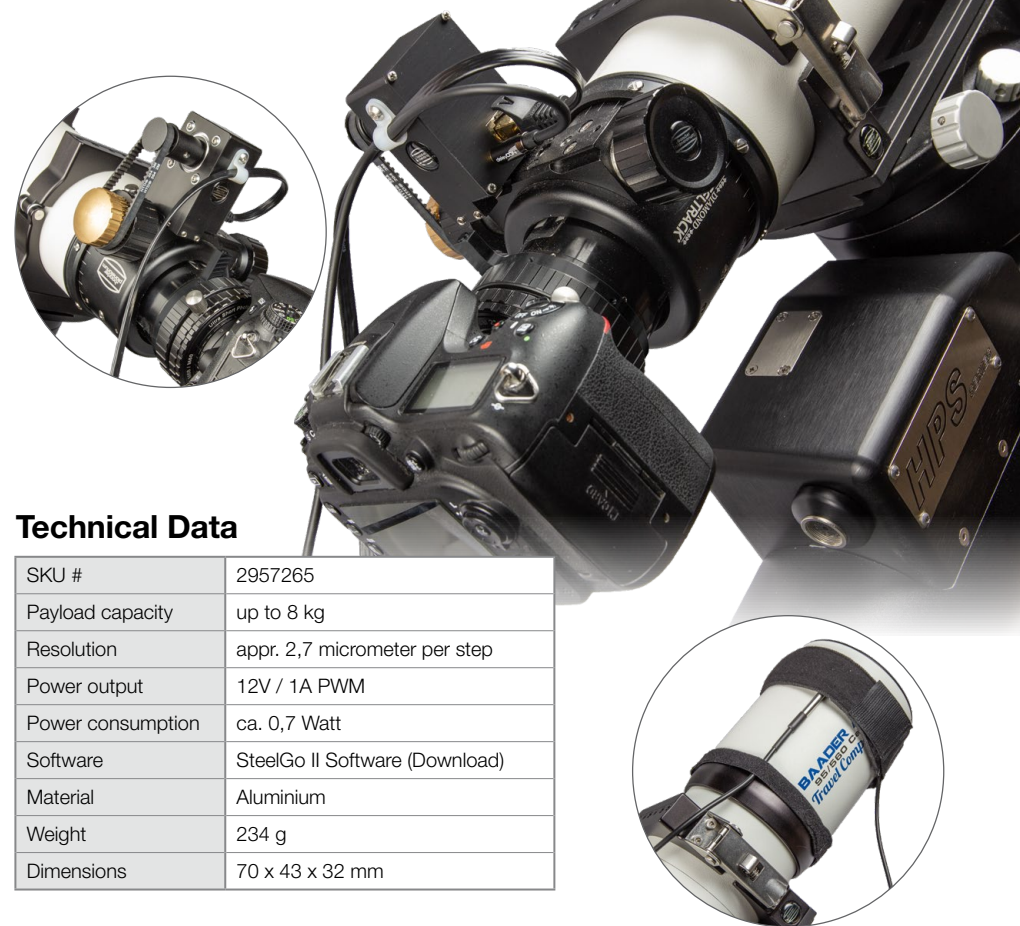

Technical Data

SKU #	2957265
Payload capacity	up to 8 kg
Resolution	appr. 2,7 micrometer per step
Power output	12V / 1A PWM
Power consumption	ca. 0,7 Watt
Software	SteelGo II Software (Download)
Material	Aluminium
Weight	234 g
Dimensions	70 x 43 x 32 mm

Steeldrive II Motor Unit – Highlights #2957265

- High-precision focusing motor for heavy loads (up to 8 kg), incl. temperature sensor, supports temperature compensation. Steeldrive II Control Unit #2957260 is required for operation
- Works with every Baader Steeltrack® focuser (Classic and Diamond)
- Can also be used with other focusers like e. g. FeatherTouch. Adapters for other focusers are in development, but not included in the scope of delivery.
- Contactless Homing Sensor enables precise homing and repeatable approach of saved absolute positions – perfect for remote-observatories.
- Can be controlled either with the powerful SteelGo II software or through the ASCOM driver. Needs Steeldrive II Control Unit #2957260
- Made in Germany: The housing is CNC-milled from Aluminium in our factory. The electronical boards are made by a German company according to our specifications.

Contents

Introduction and Highlights	2
Technical Data	3
1. Scope of Delivery and Optional Accessories	4
2. Dimensions and Ports	5
3. Installation of the Steeldrive II Motor Unit	6-7
4. Backlash and Slip	8
5. Homing-Sensor	8
Installation of the Magnet Holder	9
Installation of the optional Metal-Magnet-Ring	10

1. Scope of Delivery

Scope of Delivery of the Motor Unit for Steeltrack® Focusers

1. Steeldrive II (SD II) motor unit for Steeltrack® focusers
2. CAT 7 cable (3 m) to connect the control unit
3. SD II toothed belt for Steeltrack® focuser
4. Temperature sensor with phone connector.
Can be used with SD II motor units or SD II control units
5. Magnet holder for homing-sensor – can be used with Diamond Steeltrack® and similar focusers, includes mounting screw
6. Allen key (2 mm)
7. Velcro tapes (cable ties) for strain-relieving cable management



Optional Accessories:

- Additional temperature sensor #2957263
- Metal Magnet Ring for Homing-Sensor – fitting for Baader Diamond Steeltrack® focusers #2957264
- Mini DIN / Cinch adapter cable to connect heat pads (dew shield heaters) #2957262

For further accessories like adapters to use the SD-II motor unit with other focusers, please visit www.baader-planetarium.com/en/bds

2. Dimensions and Ports

Dimensions

See images to the right and below.

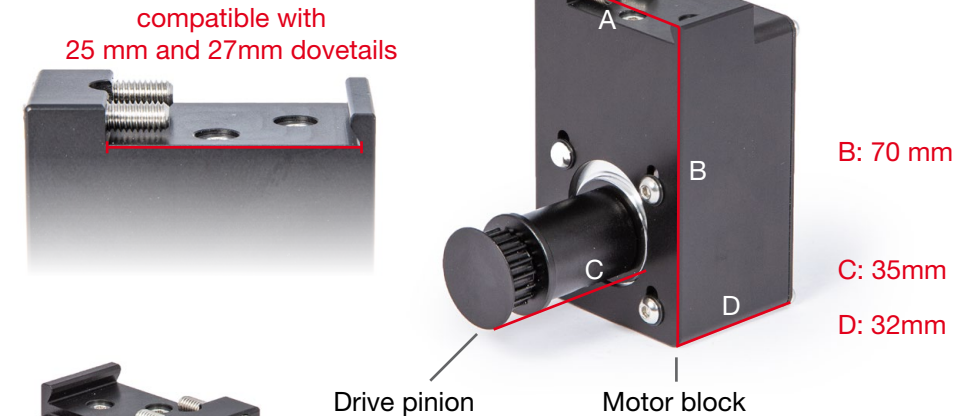

Ports

1. RJ45-port, connects to the control unit (*no network functionality*)
2. 3.5 mm phone jack for temperature sensor
3. Strain relief for the connected cables

Please note

The SD II motor unit is designed to be operated with the SD II control unit. If you want to use the motor without the SD-II Control unit, you can find a diagram with the pin configuration for a self-made control to the right.

MOTOR A+
MOTOR A
MOTOR B
HALL SENSOR
+5V
MOTOR B+
TEMP 0
GND

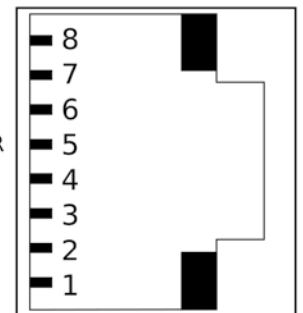

3. Installation of the Steeldrive II Motor Unit

at Baader Steeltrack® focusers

The motor unit of the Baader Steeldrive II – abbreviated as SD II in the further text – can easily be attached to focusers with a dovetail clamp. A Baader Diamond Steeltrack® focuser – abbreviated BDS in the further text – already provides a matching 25mm dovetail, as well as the previous Classic 2" or 3" Steeltrack® models (25 mm or 27 mm dovetail).

Other focusers can also be used, but they may need other adapters, which will either be offered by us in the future or must be custom-made by you.



In addition to these instructions: see the assembly in 9 steps as a video

http://bit.ly/sd2_motor-en

Step-by-step-manual

1. At first remove the knurled screw ① of the slip guard. This screw is not necessary when the SD II is installed.
2. Use the adjusting screw ② to make sure that the focuser tube will not slip under the weight which you attach to your focuser. Tighten it CAREFULLY until you can move the fine adjustment knob by pulling the focuser tube, without the focuser tube slipping through.
3. Loosen the two M4 clamping screws ③ at the side of the SD II motor unit with the included 2 mm Allen key, until you can move the clamp over the dovetail of the propulsion unit (see above). The M4 screws do not have to be removed, you just have to loosen them far enough until the motor unit can be brought into position.
4. Place the belt loosely over the brass knob of the BDS's slow motion control and then over the drive pinion of the motor unit.
5. Now put the motor with pulley on the focuser. Make sure that the outer sides of

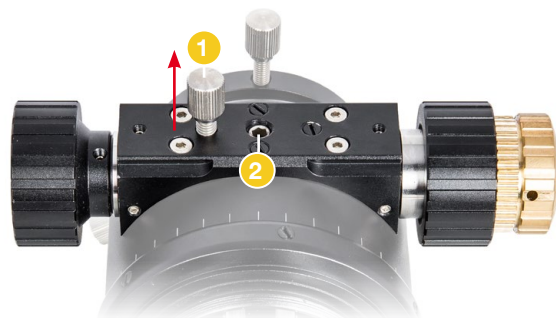

Img. 1: Propulsion unit of a BDS focuser



Abb. 2: The SD II motor unit

both focuser and motor are flush with each other (Img. 3). Now hand-tighten the two Allen screws evenly. If you use too much force, there will be pressure marks in the anodising.

6. *If necessary:* Loosen the two grub screws ④ at the drive pinion on the motor axis. Move the drive pinion on the axis, until the gear rings are flush with each other (Img. 3, red arrow). Then retighten the grub screws. If the adjustment travel is not sufficient, you can also loosen the clamping screws ③ again to move the complete motor unit.
7. If necessary, loosen the four allen screws ⑤ which keep the motor in its place.
8. Now slightly push the drive pinion until the pulley is slightly under pressure (Img. 4) and tighten the four screws again. A good rule for the right pressure is that you should be able to twist the pulley at its longest part for 90° without applying force. If in doubt: **better keep it too loose than too tight.** If the pulley is too tight, it can happen that the SD II can't move the focuser and will stall.

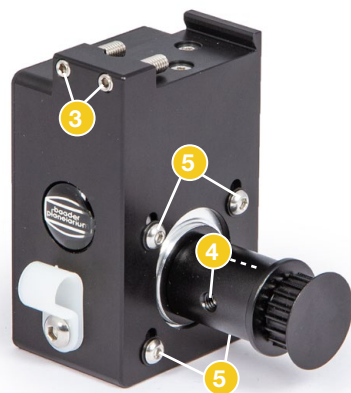
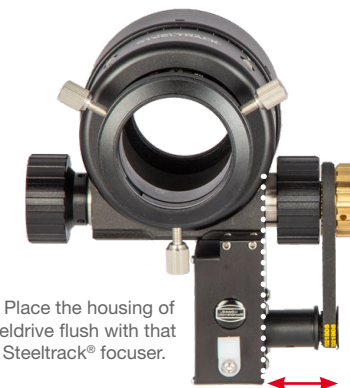

Img. 3: Place the housing of the Steeldrive flush with that of the Steeltrack® focuser.

9. Once the adjustment screws are tightened again, please check if the pulley can be moved easily by hand, without any lateral movement. If not, you need to repeat the procedure starting at step 6. If the pulley does not move laterally, but has too much or too little tension, start again at step 7.



Img. 4: Move the motor inside of its housing until the toothed belt is under a good pressure.

4. Backlash and Slip

The Baader Diamond Steeltrack® focusers are by design (Crayford focuser) **free of backlash**. In addition, the Baader Diamond Steeltrack® is free of the typical slip of Crayford focusers because of the diamond micro-gear which connects the focusing tube with the drive axle.

The following applies for all other focusers: Too much play in the focusing mechanism of rack-and-pinion-focusers leads to less precise positioning. If possible, this should be fixed at the focuser. This slippage is not caused by the SD II, because the propulsion of the focuser and the drive of the SD II are always firmly connected to each other through the toothed belt.

Please note: You can still move the Steeltrack® manually. To protect the Steeldrive from damage, you should unplug the connecting cable between motor and control unit.

Focus can also be lost if the focuser wasn't adjusted correctly. This happens most often if a heavy load is attached to the focuser. If the focuser slips, you should adjust it carefully so that just enough pressure is applied to the focusing tube, so that it doesn't slip any longer. Please refer to step 2 of the installation instructions (page 6).

The 1:10-reduction of a focuser can also introduce some slip, so that after some movements the focuser will not return exactly to the same position. Simply move the focuser back to its initial position (zero it), then the position will be calibrated again, because the homing-sensor measures the exact position.

5. Homing-Sensor

Hall-Effect-Sensor

The zero-position of the focuser is determined contactless by a magnet using the Hall-effect. This way, the focuser can be positioned with a very high precision.

The SD II can also be used wi-

thout this sensor, because its absolute position is stored in an EEPROM and isn't lost even in the event of a power failure. But because of the slip which can occur in every reduction gear box, there may be some errors which add up over time if the focuser is often moved in both directions. With the homing sensor, the exact zero-position of the focuser can be determined again, even during remote controlled operation.

To achieve the most precise positioning, the homing sensor must be the only end stop for the zero position. That's why the focuser doesn't move to the mechanical end stop. Because of this, the millimeter scale on the focuser tube does no longer show the absolute position.

Installation of the Magnet Holder

A simple, 3D-printed magnet holder is included with the SDII motor unit. It is used to mount the magnet on the 2" eyepiece clamp of the focuser. It can easily be mounted on the Diamond Steeltrack® with a screw, or you can glue it onto other focusers. Please note that the magnet may be placed too high or too low on other focusers, and you may need to adapt it.

Remove one of the three locking screws from the 2" eyepiece holder and attach the magnet holder **6** as shown in the image to the right with the included screw **7**. Alternatively, you can also glue the magnet holder onto the focuser, if you want to use all three clamping screws in the future, too.

Now, you need to align the eyepiece holder with the magnet to the sensor of the motor unit. To do so, loosen the locking screws with which the clamp is attached to the focuser tube. Use the Allen key which was included with the BDS for this. Then, rotate the clamp according to the image to the right and tighten the screws again.



In addition to these instructions: see the magnet holder installation in 3 steps as a video http://bit.ly/sd2_magnet-en



Img. 5: The magnet holder is attached instead of the lower clamping screw at the focuser tube. It must be parallel to the SD II.

Installation of the optional Metal Magnet Ring #2957264

Instead of the simple magnet holder which is included in the scope of supply, you can also use the optional magnet ring made of metal. Then the full functionality of the original eyepiece holder is preserved. Especially if you have upgraded your Diamond Steeltrack® e. g. with a 2" Clicklock S58 eyepiece holder #2956258 or if you use an adapter to a thread, you can install the magnet for the homing sensor easily.

To install the magnet ring, at first you need to remove the 2" eyepiece holder or the thread adapter for e.g. T-2, M48 or M68.

To do so, remove the six Allen screws **8** and remove the eyepiece holder. Now insert the magnet ring in such a way that the holder of the magnet (for the homing sensor) is in flush with the housing of the SD II (Img. 7). Retract the focuser completely for this.

Now lock the sensor ring with the six Allen screws **8**. Finally attach the eyepiece clamp at the metal ring. Tighten the screws **9** firmly.



Img. 6: The screws to attach the metal magnet ring.

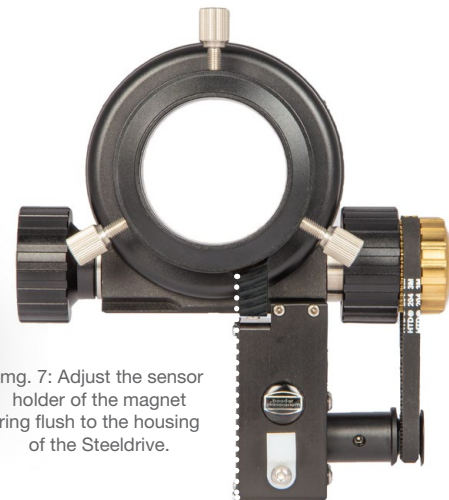

Img. 7: Adjust the sensor holder of the magnet ring flush to the housing of the Steeldrive.



Metal-Magnet-Ring for Homing-Sensor #2957264, Steeltrack® with opt. S58 ClickLock Clamp #2956258

Advertisement

BDS
(Baader Diamond Steeltrack®)







2957220
BDS-SC



2957210
BDS-RT



2957230
BDS-NT



STEELTRACK® PROPERTIES

- True diamonds form a micro-gearred high precision drive system
- Zero backlash, zero cogging, and zero flexure
- Lifts a payload of 6 kg (13 lbs), without slipping or excessive bearing preload
- 10 mm unbreakable Instrument Grade Roller-Bearings instead of simpler Ball Bearings – no Teflon anywhere
- 1:10 Stainless Steel fine-focus mechanism, ready for Steeldrive II
- 55 mm inner clear diameter, to prevent vignetting, and many more features

Steeltrack®, Steeldrive and many adapters for telescope- and eyepiece-side at

www.baader-planetarium.com/en/bds

STEELDRIVE II

High precision, temperature compensating
focusing motor for heavy loads

Set with Motor and Control Unit: #2957165



**Baader
Steeldrive II
Motor unit**

#2957265

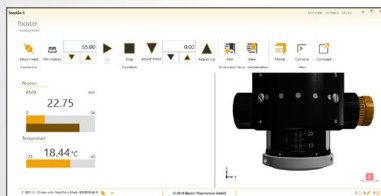

SteelGo II Software-Download:

www.baader-planetarium.com/steelgo2

**Baader
Steeldrive II
Controller**

#2957260

© 2019 Baader Planetarium GmbH | All rights reserved. Products or manual can be changed without further notice. We reserve the right for errors. Reproduction of this manual – even in part – is not permitted without the written consent of BaaderPlanetarium GmbH.



BAADER PLANETARIUM

Zur Sternwarte 4 • D-82291 Mammendorf • Tel. +49 (0) 8145 / 8089-0 • Fax +49 (0) 8145 / 8089-105
www.baader-planetarium.com • kontakt@baader-planetarium.de • www.celestron.de

G
M
B
H